



TRIED-AND-TESTED
LITHIUM SOLUTIONS FOR MHI



OneCharge

COMBILIFT
LIFTING INNOVATION

**AISLE
MASTER**



CUSTOM series

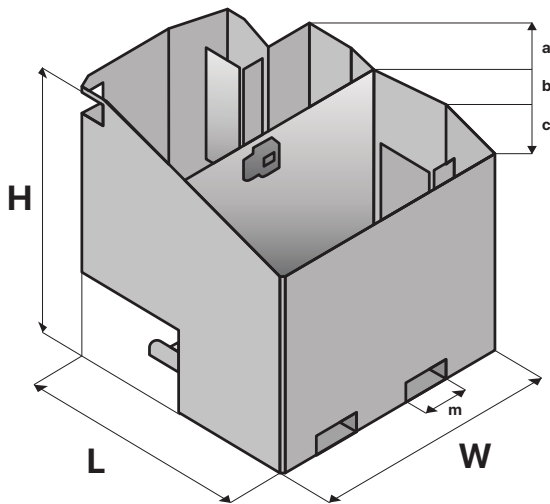

OneCharge CUSTOM Series battery box.

**You supply the technical
drawings, we'll build you a
OneCharge Battery!**



Full integration with ALL Aisle Master & CombiLift electric lifts

- 50 different models to fit Aisle Master and CombiLift Electric Lifts
- Battery to truck communication using CAN protocol
- Lifts that require dual cases usually get all of the required power (and more) in one case! (and just ballast in the other)
- OneCharge batteries are compatible with many different chargers! 0.5C to 1.5C charging available!



Performance

- One battery will last through 3 shifts while opportunity charging
- There is little or no voltage drop with Li-ion batteries
- Reduce or eliminate heat that can damage lift truck components
- Less lift truck component wear
- Fast lifting and travel speeds at all levels of discharge



Improve Safety and Sustainability

- Eliminate risk of changing heavy batteries during a shift
- No acid fumes or spills
- Reduce use of electricity, less waste, 99% recyclable



Lower Total Cost of Ownership

- Save 20-40% in 2-4 years (compared to LP, Gasoline, Diesel or Lead-acid)
- Double the cycle life of a lead-acid battery
- Save the labor dollars to change batteries each shift
- Save the labor or contract dollars to water batteries
- Return battery room square footage to profitable task
- Reduce or eliminate costs to cool charging areas
- Reduce electricity use as much as 30% due to more effective energy conversion during charging

CUSTOM Series

Standard Equipment on Every OneCharge Battery

- Heavy Duty Steel Outer Case
- Battery Management System
- Battery Discharge Indicator
- Speaker
- On/OFF Switch
- DB9 Connector - Laptop Connection
- Output Connector to Lift (Anderson SB)
- Input Charging Port (Euro 320)
- Wireless Capability

Specifications:

Class of lift truck	Class I, II
Voltage	24 / 48 / 72V
Capacity	210 – 840 Ah
Charging time	45 min - 2 hours



More effective Warehouse Space Utilization using Specialty Equipment from Combilift or Aisle-Master

Options available:

- Extra weight
- Wired External BDI
- Hardware and software for CAN Protocol communication with Combilift
- Direct Cable Package - Charging cables and connector custom length for any Make/Model
- External Equipment Control Package (External Power Option)
- Package for Cooler – Insulation; +32 - +68 degrees
- Package for Freezer - insulation, heater and top seal kit; -22 to +68 degrees
- Top seal kit for cover, cables, BMS (Dust and overspray only, no pressure washers!)
- OneCharge Management System data access

Truck Lift Models:

Combilift

C6000ET, C8000ET, C10000ET,
C12000ET, C6000GTE, C11000GTE,
C6000STE, C8000STE, C17000ESL,
C14000ET, C17300ET, C20000ET,
CBE5000, CBE6000, CBE8000,
CS1850, CS2200, CS2750, CS3200,
CS3850, CS4400, WR, WR4

Aisle-Master

AM33E, HE, NE, SE, SHE
AM44E, HE, SE, SHE, WE, WHE
AM55E, HE, SE, SHE, WE, WHE
AM66E, HE, SE, SHE, WE, WHE